



FORD PERFORMANCE

M-5230-BR3 & BR7

Model 2021 +

Bronco 2.3L & 2.7L Sport High Clearance Exhaust

NO PART OF THIS DOCUMENT MAY BE REPRODUCED WITHOUT PRIOR AGREEMENT AND WRITTEN PERMISSION OF FORD PERFORMANCE PARTS © Ford Motor Company 2020

PRIOR TO INSTALLATION READ THESE INSTRUCTION COMPETELY
For questions, Call the FORD PERFORMANCE Techline 1-800-367-3788

Please visit <https://www.performanceparts.ford.com> for warranty information

OVERVIEW:

The use of a floor hoist is recommended for this installation. If you do not have access to one, use a hydraulic floor jack and jack stands to raise the vehicle.

!! CAUTION: JACK STANDS MUST BE USED ON A LEVEL SURFACE AND BE SECURELY SEATED. FAILURE TO DO SO MAY RESULT IN PERSONAL INJURY OR VEHICLE DAMAGE! !

Base Kit Includes:

<u>Find No.</u>	<u>Qty:</u>	<u>Description</u>
1	1	Rear Muffler Assembly
2	1	Hanger Bracket
3	2	Nut: M8 x 1.25
4	1	Clamp

Note:

1. Determine the engine size of your 2021 Ford Bronco.
2. The hanger locations are different based on engine size.
3. Immediately inventory your kit to ensure all of the necessary parts are included.

Factory Ford shop manuals are available from Helm Publications, 1-800-782-4356



FORD PERFORMANCE

M-5230-BR3 & BR7
Model 2021 +
Bronco 2.3L & 2.7L Sport High Clearance Exhaust

2021 Ford Performance Bronco 2.3L High Clearance

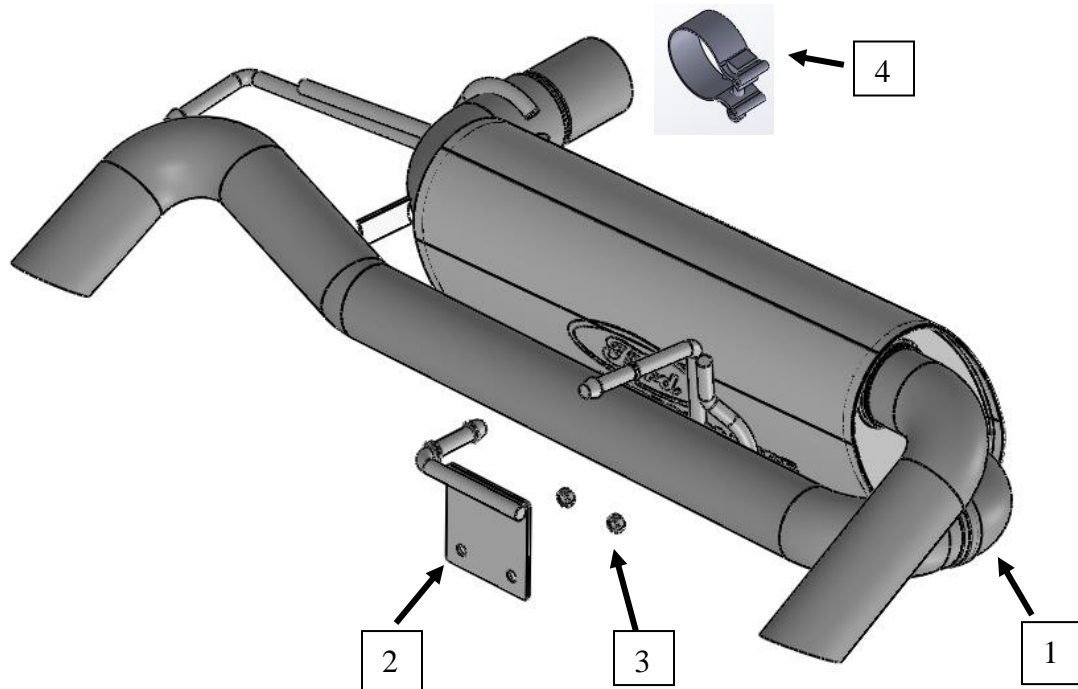

2021 Ford Performance Bronco 2.7L High Clearance

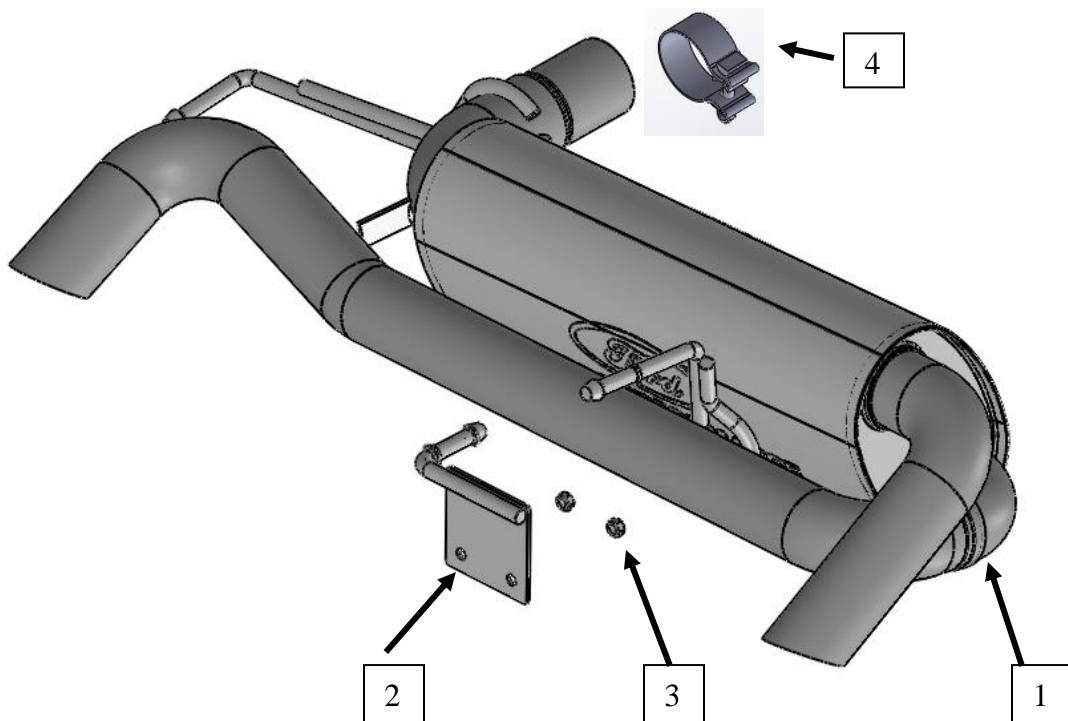

Factory Ford shop manuals are available from Helm Publications, 1-800-782-4356

REMOVAL INSTRUCTIONS:

STEP 1: Position vehicle on hoist, put in park.

STEP 2: Loosen the clamp. *Torque is 35 lb.ft (48 Nm)*

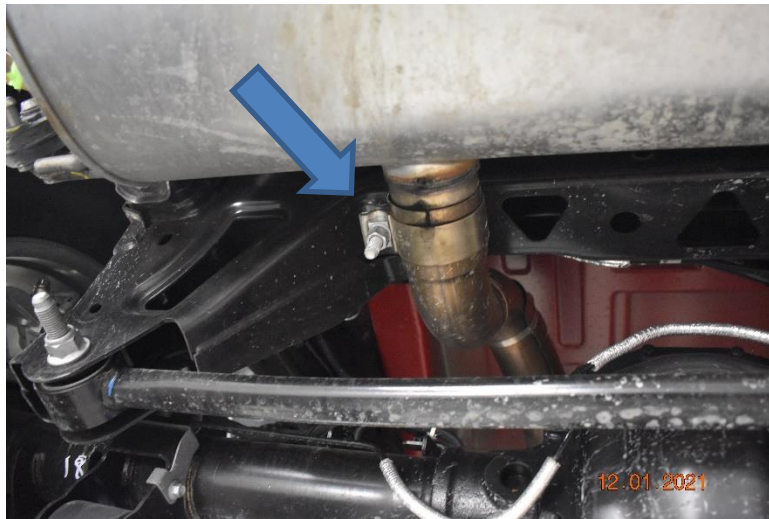

STEP 3: Lubricate all hangers shown below, pull off factory muffler hangers.

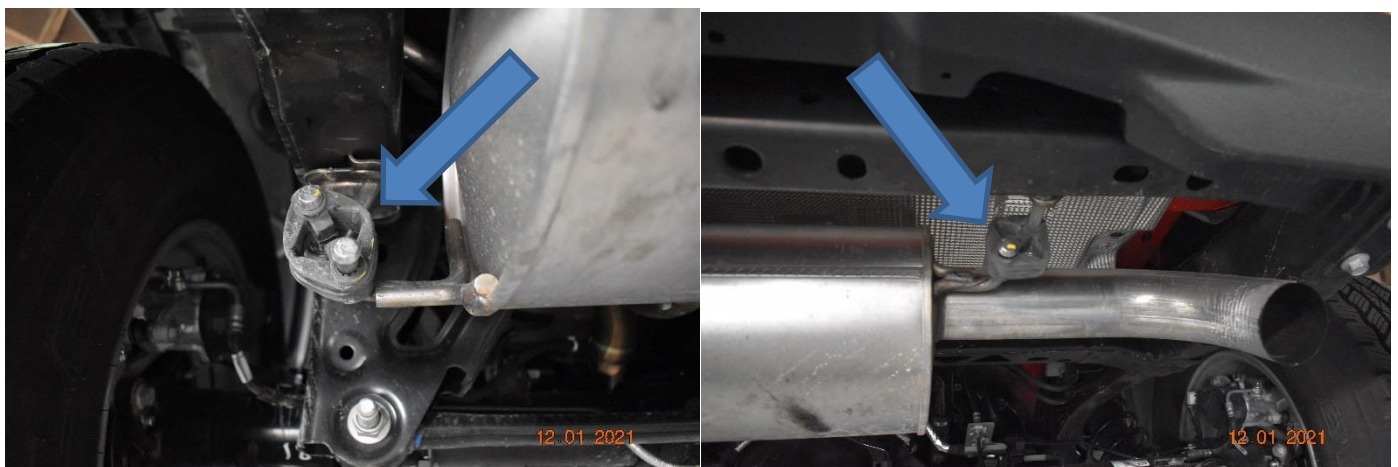

STEP 4: Remove factory system from vehicle.



FORD **PERFORMANCE**

M-5230-BR3 & BR7

Model 2021 +

Bronco 2.3L & 2.7L Sport High Clearance Exhaust

INSTALLATION INSTRUCTIONS:

STEP 1: Lubricate all isolators. Slide the supplied clamp over the factory pipe. Then insert the new system inlet into the expanded factory pipe. Slide the clamp into position over the joint, do not tighten.



STEP 2: Place the hanger bracket over the studs of the factory bracket and attach using the nuts supplied.



Factory Ford shop manuals are available from Helm Publications, 1-800-782-4356



FORD PERFORMANCE

**M-5230-BR3 & BR7
Model 2021 +
Bronco 2.3L & 2.7L Sport High Clearance Exhaust**

Step 3: Place (2) hangers into the rubber isolators.

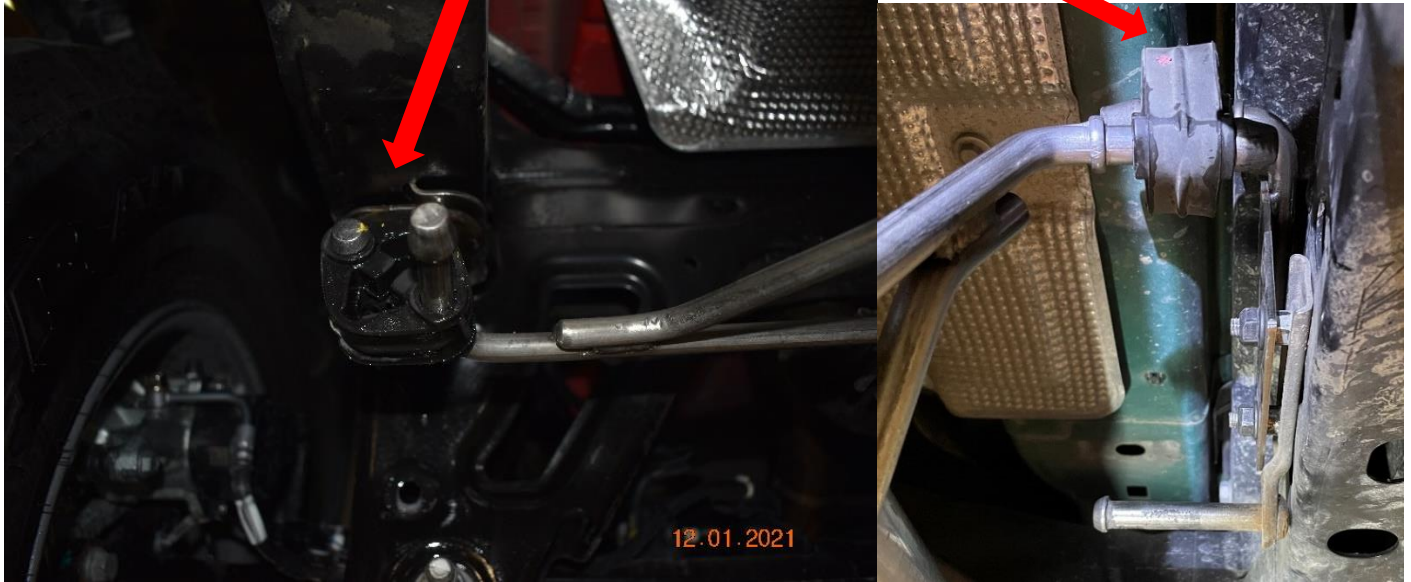

Note: Actual system will only have 1 hanger

STEP 4: Check your exhaust system for proper clearance under the vehicle and also for tip alignment, tighten the clamp to 32-35 ft. lbs.

STEP 5: Start vehicle and check for any leaks. If any leaks are found, determine cause (such as loose or incorrectly positioned clamp) and repair as necessary.



FORD **PERFORMANCE**

**M-5230-BR3 & BR7
Model 2021 +
Bronco 2.3L & 2.7L Sport High Clearance Exhaust**



Congratulations!!! You have completed the installation of your new Ford Performance Parts Exhaust Kit.

Note: When you first start your vehicle after the installation of your new Ford Performance Parts Exhaust System, there may be some smoke and fumes coming from the system. This is a protective water based coating used in the manufacturing of mandrel bent performance exhaust tubing. This is not a problem and will disappear within a very short period of time after the exhaust has reached operating temperatures.

Factory Ford shop manuals are available from Helm Publications, 1-800-782-4356